

## SPECIFICATION

| CONTROL SYSTEM DESCRIPTION                              |  |
|---|--|
| Configurable 4-20 mA outputs for glass level reading    | 4  |
| Digital input ( <i>compressed air pressure switch</i> ) | 1  |
| Communication links                                     | Modbus RTU TCP/IP                          |
| Optional link communication                             | Profinet                                   |
| HMI interface   | Touch screen screen 15"                    |
| Control panel dimensions                                | 500x400x250 mm                             |
| Control panel operating system                          | WIN10IOT                                   |
| Quantities controlled and recorded on log file          | Glass Level, antenna temperature           |
| Recording of measured quantities                        | Recording, trend, research                 |
| Alarm management  | Active alarms visualization, alarm history |
| Cable lenght between antenna an panel max               | 35 mt                                      |

## TECHNICAL CHARACTERISTIC

| DESCRIPTION  |                          |
|--|--------------------------|
| Emitted power ( <i>EIRP - Effective Isotropic Radiated Power</i> ) | <100 mW                  |
| Antenna beam angle   | ±2°                      |
| Distance measurement range   | 0.3-5 mt                 |
| Reading hole diameter  | 40-80 mm (optimal 50 mm) |
| Measurement accuracy distance variation                            | ±5 microns               |
| Max antenna temperature  | 120° C                   |
| Maximum antenna installation ambient temperature                   | 160° C                   |
| Cooling air supply pressure  | 4-6 bar(g)               |
| Adjustable feet for positioning, running                           | +/- 10 mm                |

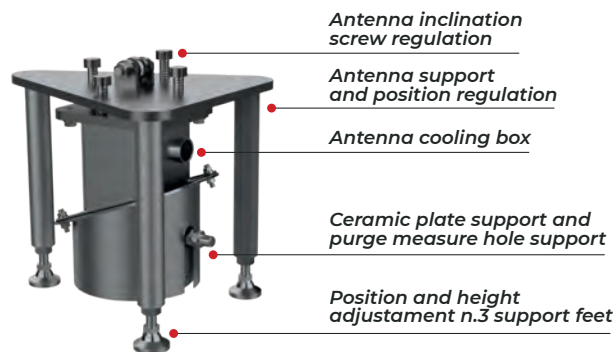

### CONTROL PANEL



Follow us    

ALL TECHNOLOGY MADE IN ITALY

[glassservice.it](http://glassservice.it)

**glass**<sup>®</sup>  
SERVICE

# RADAR LEVEL MACHINE



# RADAR CONTROL MACHINE

The radar glass level is the evolution of the already proven radar glass level built by Glass Service in 2012, where Glass Service was the first in the world to develop interferometric radar technology.

The new level meter has been developed on a new radar technology including all the improvements in electronics and computational performance of recent years.

The new system is made with a small radar antenna size of only 130x130 mm and is easily adaptable to existing working ends or forehearths. Inserted in a mechanical support of only 265x265 mm.

The measurement performance is significantly improved in terms of accuracy and reliability, as well as the measurement range that covers a measurable distance from the antenna of 300-5000 mm, which is very wide.

High-frequency 100 Hz measurement sampling allows the level of molten glass to be monitored exactly and the signal to be filtered according to furnace control needs.

The reading accuracy is also very high at 0.05 mm

*Mounting the antenna installed on top of the WE or FH with a very small and compact structure minimizes errors due to thermal expansion of the antenna support structures.*



The antenna mount includes simple adjustment systems to adjust the positioning and orientation of the radar beam.

**The antenna is separated from the combustion chamber of the WE or FH by a plate of special temperature-resistant ceramic material.**

We recommend the use of a light blow of compressed air to keep the reading oven clean of any deposits or encrustations.

- The antenna is equipped with a compressed air inlet for cooling.
- The compressed air is managed by a small pneumatic panel supplied with the machine.
- No cooling water is required. The antenna is capable of operating at up to 120°C.
- Thanks to the compressed air cooling system, it can be installed in an environment up to approx. 160 °C.



## CONNECTION DIAGRAM

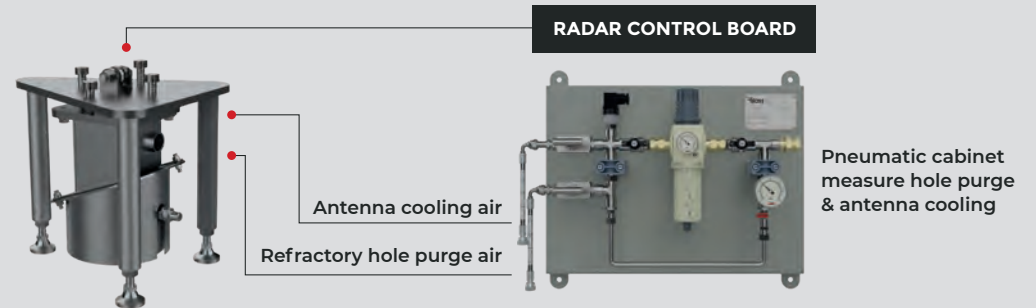

## DIMENSIONS

